



757 Tire Hill Road • Johnstown, PA 15905
Phone: 814.288.5969 • Fax: 814.288.5970
<http://www.jaircompressors.com>

Introduction

Congratulations on the purchase of your new J-Air compressor! You can be assured that this tool has been constructed with the highest level of precision and accuracy. Each component has been rigorously tested by technicians to ensure the quality, endurance and performance of this air compressor.

By reading and following the safety, operation, maintenance and troubleshooting steps described in this manual, you will receive years of trouble-free operation.

The manufacturer reserves the right to make changes in price, color, materials, equipment specifications or models at any time without notice.

If you have any questions or comments about this or any J-Air compressor, call us at 1-814-288-5969.

Inspection of Compressor

Inspect for signs of obvious or concealed freight damage. Report any damage to the delivering freight carrier immediately. Be sure that all damaged parts are replaced and any mechanical problems are corrected prior to the operation of the air compressor. The air compressor serial number is located on the deck of the air compressor. Please write the serial number in the space provided in the service section for future reference.

Safety Instructions

⚠ Warning! Read and understand all instructions before operating this compressor. Failure to follow all instructions listed below may result in electric shock, fire and/or serious personal injury.

Save these instructions!

⚠ Warning: Some dust created by this product contains chemicals known to the State of California to cause cancer, birth defects or other reproductive harm. Some examples of these chemicals are:

- compounds in fertilizers
- compounds in insecticides, herbicides and pesticides
- arsenic and chromium from chemically treated lumber

To reduce your exposure to these chemicals, wear approved safety equipment such as dust masks that are specially designed to filter out microscopic particles. **Avoid inhaling vapors and dust, and wash hands after using and handling.**

Improper operation or maintenance of this product could result in serious injury and property damage.

The user of the air compressor must understand these instructions. Each person operating the air compressor must be of sound mind and body and must not be under the influence of any substance, which might impair vision, dexterity, or judgment.

Air Tank

The tank on your air compressor is designed and may be UM coded (for units with tanks greater than 6 inch diameter) according to ASME Section VIII, Division 1 rules. All pressure vessels should be inspected once every two years. To find your state pressure vessels inspector, look under the Division of Labor and Industries in the government section of a phone book.



The following conditions could lead to a weakening of the tank, and result in a violent tank explosion:

1. **Failure to properly drain condensed water from the tank can rust and cause thinning of the steel tank.** Drain tank daily or after each use. If tank develops a leak, replace it immediately with a new tank or new compressor outfit.
2. **Modifications or attempted repairs to the compressor tank.** Never drill into, weld, or make any modifications to the tank or its attachments.
3. **Do not modify the safety valve, or any other components that control tank pressure.** The tank is designed to withstand specific operating pressures. Never make adjustments or parts substitutions to alter the factory set operating pressures.

Attachments and Accessories

Exceeding the pressure rating of air tools, spray guns, air-operated accessories, tires and other inflatables can cause them to explode or fly apart, and could result in serious injury. Follow the equipment manufacturers recommendation and never exceed the maximum allowable pressure rating of attachments. Never use the compressor to inflate small low-pressure objects such as children's toys, footballs, basketballs, etc.



Risk of Explosion or Fire

Always operate the compressor in a well-ventilated area free of combustible materials, gasoline or solvent vapors. If sparks



from compressor come into contact with flammable vapors, they may ignite, causing fire or explosion. If spraying flammable materials, locate compressor at least 20 feet up wind from spray area. An additional length of hose may be required.

Store flammable materials in a secure location away from compressor. Restricting any of the compressor ventilation openings will cause serious overheating and could cause fire. Never place objects against or on top of compressor. Operate compressor in an open area at least 3 feet away from any wall or obstruction that would restrict the flow of fresh air to the ventilation openings.

Risk From Flying Objects

The compressed air stream can cause soft tissue damage to exposed skin and can propel dirt, chips, loose particles and small objects at high speed, resulting in serious injury. Always wear ANSI Z28.1 approved safety glasses with side shields when using the compressor. Never direct air stream at people or animals. Use only OSHA approved air blow guns.

Risk to Breathing

The compressed air from your compressor is not safe for breathing! The air stream may contain carbon monoxide, toxic vapors or solid particles. Never inhale air from the compressor either directly or from a breathing device connected to the compressor.



Spray materials such as paint, paint solvents, paint remover, insecticides, weed killers, etc. contain harmful vapors and poisons.

Note: Operate air compressor only in a well-ventilated area. Read and follow the safety instructions provided on the label or safety data sheets for the material you are spraying. Use a NIOSH/MSHA approved respirator designed for use with the specified application.

Risk From Moving Parts

Always turn off the compressor, bleed pressure from the air hose and tank, and disconnect from power source before performing maintenance or attaching tools and accessories.



Keep your hair, clothing, and gloves away from moving parts. Loose clothes, jewelry, or long hair can be caught in moving parts. Air vents may cover moving parts and should be avoided as well. Do not remove the protective covers from this product. Never operate compressor with guards or protective covers that are damaged or removed. Never stand on the compressor.

Hot Surfaces

Touching exposed metal such as the compressor head, motor, or aftercooler can result in serious burns. Never touch any exposed metal parts on compressor during or immediately after operation. Compressor will remain hot for several minutes after operation. Do not move the compressor while it is running. Hot motor parts could cause burns contributing to the dropping of the compressor, damaging the compressor and/or injuring the operator.

Risk From Noise

Caution: Wear appropriate personal hearing protection during use. Under some conditions and duration of use, noise from this product may contribute to hearing loss.



Risk of Electrical Shock

Your air compressor is powered by electricity, if it is not used properly it could cause electric shock. Never operate the compressor out-doors when it is raining or in wet conditions.

Never operate compressor with guards or protective covers that are damaged or removed. Repairs by anyone other than qualified personnel can result in serious injury or death by electrocution. Any electrical wiring or repairs required on this product should be performed by authorized service personnel in accordance with national and local electrical codes.



Repair or replace damaged or worn cords immediately. The use of a ground fault circuit interrupted (GFCI) outlet is recommended and may be required in certain areas.

J-Air does not recommend the use of extension cords as this can create power loss and overheating of the motor. Use of an additional air hose is recommended rather than an extension cord. If use of an extension cord is unavoidable, it should be plugged into a GFCI found in circuit boxes or protected receptacles. When using an extension cord, observe the following:

Extension Cord Chart			
1.5 Hp Motor			
Rating	Length of Cord in Feet		
	250	500	1000
16 amp. 115V	14 Ga.	12 Ga.	10 Ga.
8 amp. 230V	16 Ga.	16 Ga.	14 Ga.
2 Hp Motor			
Rating	Length of Cord in Feet		
	250	500	1000
20 amp. 115V	14 Ga.	12 Ga.	8 Ga.
9 amp. 230V	16 Ga.	16 Ga.	14 Ga.

Grounding Instructions

In the event of a malfunction or breakdown, grounding provides a path of least resistance for electric current to reduce the risk of electric shock. This tool is equipped with an electric cord having an equipment-grounding conductor and grounding plug. The plug must be plugged into a matching outlet that is properly installed and grounded in accordance with all local codes and ordinances. Make sure that the electrical circuit to which the compressor is connected provides proper electrical grounding, correct voltage and adequate fuse protection. Do not modify plug provided: if it will not fit the outlet, have the proper outlet installed by a qualified electrician.

Improper connection of the equipment-grounding conductor can result in a risk of electric shock. The conductor with insulation having an outer surface that is green with or without yellow stripes is the equipment-grounding conductor. If repair or replacement of the electric cord or plug is necessary do not connect the equipment-grounding conductor to a live terminal.

Check with a qualified electrician or service personnel if the grounding instructions are not completely understood or if in doubt as to whether the tool is properly grounded.

Use only 3-wire extension cords that have 3-prong grounding plugs and 3-pole receptacles.

Grounded tools intended for use on a supply circuit having a nominal rating less than 150 volts: This tool is intended for use on a circuit that has an outlet that looks like the one illustrated in Figure A. The tool has a grounding plug that looks like the plug illustrated in Figure A. temporary adapter, which looks like the adapter illustrated in Figures B and C, may be used to connect this plug to a 2-pole receptacle as shown in Figure B if a properly grounded outlet is not available. The

temporary adapter should be used only until a properly grounded outlet can be installed by a qualified electrician. The green-colored rigid ear, lug, and the like, extending from the adapter must be connected to a permanent ground such as a properly grounded outlet box.

The adapter (C) is not for use in Canada.

Always store compressor in a horizontal position, on all four rubber mounts.

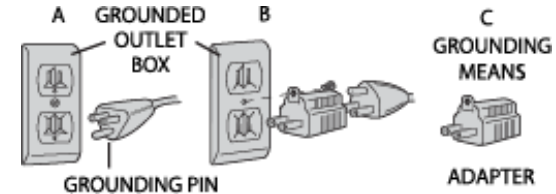

Features

Dual Control

This feature allows the compressor to operate in either the constant run or the stop/start mode of operation. The **pilot valve** is used to control the compressor when operating in the constant run mode. The **pressure switch** is used to control the compressor when operating in the stop/start mode. The mode of operation is determined by the amount of time the compressor will be required to supply air. If the demand for air is infrequent, then the unit should be set up for stop/start operation to minimize unnecessary run time and to save energy. If there is a frequent or extended demand for air, and/or the unit is located in a remote area where access to the compressor is difficult, the unit should be set up for constant run to minimize the number of times the motor must start in an hour to ensure good motor life.



Dual Voltage

This feature allows the compressor to operate in either 115- or 230-volt environments. The advantage of running in the 230-volt range is a lower current draw. Lower current draw may be necessary in areas with a poor power source. Lower current also reduces operating costs. If running in the 230-volt mode, the plug end must be replaced with the appropriate plug.



Pilot Valve

Pilot valves are used to maintain a constant pressure range while running continuously. The pilot valve may be used to operate a discharge line unloader or an unloading device in the compressor head. Unloading occurs when the receivers (tanks) reach a preset cut-out pressure. The pilot valve opens, actuating the unloading device that allows the compressor to run in an unloaded mode. When the tank pressure drops to the preset cut-in pressure, the pilot valve closes allowing the unloading device to close and the compressor once again pumps into the tanks.

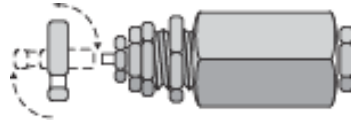

Manual Lock

The manual lock allows you to manually unload the compressor with air pressure in the tank. To operate the unloading device in the head, rotate the flip lever to an in-line position (dashed lines). Be sure to return lever to the loaded position after starting the engine, or the pump will not operate at preset pressures.

Pressure Switch

This switch (A) is used to start or stop the air compressor. Moving the switch to the "ON" position will provide automatic power to the pressure switch, which will allow the motor to start when the air tank pressure is below the factory set "cut-in" pressure. When in the "ON (AUTO)" position, the pressure switch stops the compressor from charging air when the air tank pressure reaches the factory set "cut-out" pressure. For ease of starting, this switch also has a pressure release valve located on the side of the switch designed to automatically release compressed air from the air compressor pump head and its discharge line when the air compressor reaches "cut-out" pressure or is shut off. Moving the switch to the "OFF" position will open the pressure switch contacts and stop the air compressor.

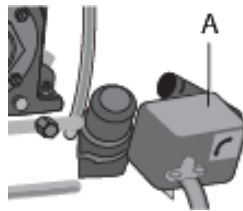

Safety Relief Valve

This valve (B) is designed to prevent system failures by relieving pressure from the system when the compressed air reaches a predetermined level. The valve is preset by the manufacturer and must not be removed or modified in any way.



Air Intake Filter

This filter (C) is designed to clean air entering the pump. To ensure the pump continually receives a clean, cool, and dry air supply this filter must always be clean and filter intake must be free from obstructions.

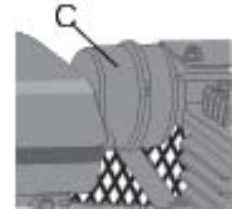

Air Tank Drain Valves

The drain valves (D) are used to remove moisture from the air tank after the air compressor is shut off.

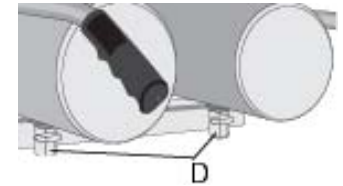

Tank Pressure Gauge

The tank pressure gauge (E) indicates air pressure in the air tank.

Regulated Pressure Gauge

The regulated pressure gauge (F) indicates the air pressure available at the outlet side of the regulator. This pressure is controlled by the regulator and is always less or equal to the air tank pressure.

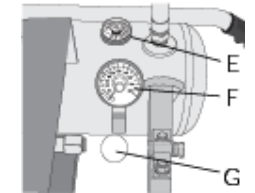

Pressure Regulator

The regulator knob (G) controls the air pressure coming from the air tank.

Common Procedures

230 Volt Operation

- *Ensure that cord requirements have been met.*
- *Ensure that motor requirements have been met.*
- *Ensure that dual voltage switch is in the proper position if so equipped.*

Cord Requirements

If it is desired to operate your compressor at 230 volts it is also necessary to replace the 115 volt plug, supplied with the motor, with a UL/CSA listed plug suitable for 230 volts and the rated current of the compressor as shown. A 230-volt plug as shown in the diagram at right can be purchased at your local hardware or electrical supply store. Follow the cord plug manufacturer installation procedures, contact a qualified electrician or call J-Air at 1-814-288-5969 for proper procedures to install the plug. The compressor must comply with all local and national electrical codes after the 230-volt plug is installed. The compressor with the 230 volt plug should only be connected to an outlet having the same configuration as the plug illustrated.

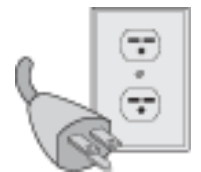

Motor Requirements

Units without a dual voltage switch

⚠ Warning: Make sure motor is disconnected from the power source before rewiring motor leads. The motor supplied with your compressor is a dual voltage, 115- / 230-volt motor. If it is desired to operate your compressor at 230 volts, single phase, it is necessary to reconnect the motor leads in the motor junction box by following the instructions given on the motor nameplate. If unsure on how to reconnect the motor leads contact J-Air or qualified electrician for proper procedures to install the plug.

⚠ Warning: Make sure that the 230-volt cord plug end is properly connected before operating in 230-volt mode.

Units With A Dual Voltage Switch

⚠ Warning: Make sure that the 230 volt cord plug end is properly connected before operating in 230 volt mode. The motor supplied with your compressor is a dual voltage, 115/230 volt motor. If it is desired to operate your compressor at 230 volts, single phase, simply move the 115/230 volt switch to the 230 volt position.

Dual Control

NOTE: Unit must remain running while performing the following adjustments:

⚠ Warning: Aftercooler, pump head, and surrounding parts are very hot; do not touch. (see Hot Surfaces)

⚠ Warning - Moving Parts: Keep your hair, clothing and gloves away from moving parts. Loose clothing, jewelry, or long hair can be caught in moving parts. Air vents may cover moving parts and should be avoided as well.

Stop-Start Mode

1. Turn compressor on. If the tank has been fully charged, bleed air from the drain valves until pump starts.
2. Turn knob on top of pilot valve (H) clockwise until fully closed.
⚠ Warning: Over tightening of this knob can cause damage to the pilot valve.
3. Allow compressor to reach cut out pressure. If compressor does not stop, drain the tank(s) until compressor begins to charge the tank(s) and readjust pilot valve knob.



Constant Run Mode

1. Turn compressor on. If the tank has been fully charged, bleed air from the drain valves until pump starts.
2. Turn knob on top of pilot valve (H) counterclockwise until fully open.
⚠ Warning: Over loosening of this knob can cause damage to the pilot valve.
3. Verify that the unit is in a constant run mode. If compressor shuts off, adjust pilot valve to a lower cut out pressure until unit continues to run.

Note: For proper operation the pilot valve cut-out pressure must be below the pressure switch cut-out pressure.

Pilot Valve Cut-Out Pressure Adjustment

Note: Unit can remain running while performing this adjustment.

⚠ Warning: Aftercooler, pump head, and surrounding parts are very hot; do not touch. (see Hot Surfaces)

⚠ Warning -Moving Parts: Keep your hair, clothing and gloves away from moving parts. Loose clothing, jewelry, or long hair can be caught in moving parts. Air vents may cover moving parts and should be avoided as well. Do not remove the protective covers from this product.

⚠ Warning: The pilot valve is brass, which is a soft metal. Do not over tighten screw as threads can strip out.

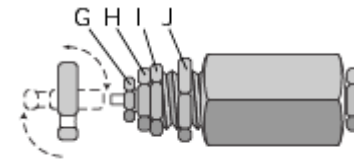

1. Hold "I" firmly and loosen nut "H".
⚠ Warning: Do not loosen screw "G" more than 1 revolution as screw is subjected to tank pressure and can burst out which can harm the user or surrounding personnel.
2. Turn screw "G" clockwise to increase cut-out pressure limit or counter clockwise to decrease cut-out pressure. (example: if the cut-out pressure on the tank gauge reads 120 psi and desired cut out is 130 psi turn screw "G" clockwise).
3. Drain air from tanks through drain valves until pump begins to charge tanks.

4. Close drain valves.
5. Monitor cut-out pressure to verify the new setting.
6. Once setting is complete, hold screw “G” firmly and tighten nut “H.”

Pilot Valve Pressure Differential Adjustment

Note: Unit can remain running while performing this adjustment.

⚠ Warning: Aftercooler, pump head, and surrounding parts are very hot; do not touch. (see Hot Surfaces)

⚠ Warning - Moving Parts: Keep your hair, clothing and gloves away from moving parts. Loose clothing, jewelry, or long hair can be caught in moving parts. Air vents may cover moving parts and should be avoided as well.

1. Hold “I” firmly and loosen nut “J.”
⚠ Warning: Do not loosen barrel “I” more than 1 revolution as barrel is subjected to tank pressure and can burst out which can harm the user or surrounding personnel.
2. Turn barrel “I” clockwise to increase differential or counter clockwise to decrease differential. (for example: if pressure differential is 100 - 130 psi and 100 - 120 psi is desired, turn “I” counter clockwise) .
Note: Too narrow of a differential can cause chatter of the pilot valve. Increase differential to eliminate chatter.
3. After desired differential is achieved, hold barrel “I” and tighten nut “J.”

Checking Compressor Pump Oil Level

⚠ Warning: Aftercooler, pump head, and surrounding parts are very hot; do not touch. (see Hot Surfaces)

1. Ensure unit is off.
2. Locate unit onto a flat horizontal surface.
3. Remove dipstick (N) from crankcase (if equipped).
4. Look for visual signs of contaminants (water, dirt, etc.) Change pump oil if contaminants are present.
5. Oil should not exceed top line on side of crankcase, the top line on the dipstick or the center of the sight glass. If necessary fill with a quality synthetic oil.
6. Replace dipstick if removed.

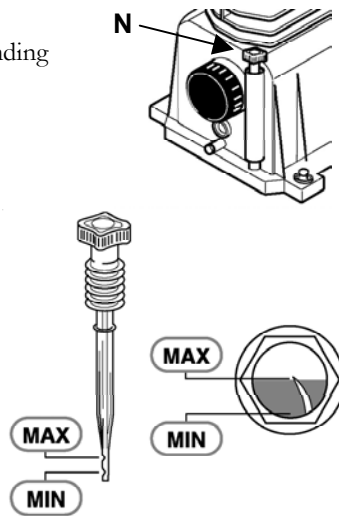

Checking Safety Relief Valve Operation

⚠ Warning: Aftercooler, pump head, and surrounding parts are very hot; do not touch. (see Hot Surfaces)

1. Ensure unit is off.
2. Ensure tanks are empty by looking at tank pressure gauge. Drain tanks if necessary.
3. Grasp wire ring on safety valve.
4. Pull and release ring a few times to ensure plunger moves in and out.

Checking Air Filter Element

⚠ Warning: Aftercooler, pump head, and surrounding parts are very hot; do not touch. (see Hot Surfaces)

1. Ensure unit is off.
2. Allow unit to cool.
3. Unscrew filter top from filter base by turning counter clockwise about 5 degrees.
4. Separate filter top from base.
5. Remove element from filter base.
6. If element needs cleaning, blow out with air. Replace element if unsure.
7. Place element back in filter base.
8. Reconnect filter top to filter base and while pushing in, rotate top clockwise 5 degrees.

Starting Unit

Follow the pre-start and start-up procedures in the operating procedure section.

Turning Unit Off

Follow the shut-down procedure in the operating procedures section.

Adjusting Regulator

1. Pull regulator knob (N) out.
2. Turn knob clockwise to increase regulated pressure and counter clockwise to decrease regulated pressure.
3. When desired pressure is shown on the regulated pressure gauge push knob in to lock.

Installing Hoses

⚠ Warning: Firmly grasp hose in hand when installing or disconnecting to prevent hose whip.

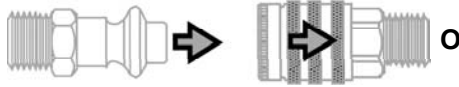

1. Ensure regulated pressure gage reads 0 PSI.
2. Grasp hose in hand at coupler location.
3. Pull back collar on female quick connect coupler (O) located on compressor.
4. Push male connector into female connector.
5. Release female connector
6. Grasp hose and pull to ensure couplers are seated.
7. Adjust regulator to desired pressure.

Disconnecting Hoses

⚠ Warning: Firmly grasp hose in hand when installing or disconnecting to prevent hose whip.



1. Ensure regulated pressure gage reads 0 PSI.
2. Grasp hose in hand at coupler location.
3. Pull back collar on female quick connect coupler located on compressor.
4. Pull male connector out of female connector.
5. Release female connector.

Draining Tanks

⚠ Warning: Tanks contain high pressure air. Keep outlet of drain away from face and other body parts. Use safety glasses when draining as debris can be kicked up into face. Use ear protection as air flow noise is loud when draining.

Note: All compressed air systems generate condensate that accumulates in any drain point (e.g., tanks, filter, aftercoolers, dryers). This condensate contains lubricating oil and/or substances which may be regulated and must be disposed of in accordance with local, state, and federal laws and regulations.

1. Ensure ON/OFF switch is in the OFF position.
2. Place a suitable container under the drains to catch discharge.
3. Grasp black lever on one drain valve.
4. Slowly rotate lever so as to gradually bleed air from tank.

5. Grasp black lever on other drain valve and rotate to approximately the same position as the first. (For twin tank units)
6. When tank pressure gauge reads 10 psi, rotate valve(s) to the fully open position.
7. Move compressor into an inclined position so drain valve(s) are at the lowest point (this will assist in removing moisture, dirt, etc. from tanks).
8. Close drain valve(s) when finished.

Preparation For Use

Initial Set-Up

Read safety instructions before setting-up air compressor.

Caution: Do not operate without lubricant or with inadequate lubricant. J-Air is not responsible for compressor failure caused by inadequate lubrication.

Compatibility

Air tools and accessories that are run off the compressor must be compatible with petroleum based products. If you suspect that a material is not compatible with petroleum products, an air line filter for removal of moisture and oil vapor in compressed air is required.

Note: Always use an air line filter to remove moisture and oil vapor when spraying paint.

Location

Caution: In order to avoid damaging the air compressor, do not allow the unit to be tilted more than 10° when operating.

Place air compressor at least 3 feet away from obstacles that may prevent proper ventilation. Keep unit away from areas that have dirt, vapor and volatile fumes in the atmosphere which may clog and gum up the intake filter and valves, causing inefficient operation.

Humid Areas

In frequently humid areas, moisture may form in the bare pump and produce sludge in the lubricant, causing running parts to wear out prematurely. Excessive moisture is especially likely to occur if the unit is located in an unheated area that is subject to large temperature changes. Two signs of excessive humidity are external condensation on the bare pump when it cools down and a “milky” appearance in compressor lubricant. You may be able to prevent moisture from forming in the bare pump by increasing ventilation or operating for longer intervals.

Electrical

Refer to the safety instructions before using unit. Observe extension cord safety instruction if necessary. Always shut off the air compressor switch before removing the plug from the receptacle.

Noise Considerations

Consult local officials for information regarding acceptable noise levels in your area. To reduce excessive noise, use vibration mounts or silencers, relocate the unit or construct total enclosures or baffle walls. Contact your local service center or call J-Air at 1-814-288-5969 for assistance.

Transporting

⚠ Warning: Unit weighs more than 160 lbs. Do not move or lift without assistance.

When transporting the compressor in a vehicle, trailer, etc. ensure that the tanks are drained and the unit is secured and placed on a flat horizontal surface. Use care when driving so to avoid tipping the unit over in the vehicle. Damage can occur to the unit or surrounding items if unit is tipped. Use a ramp if loading or unloading the unit from a height of more than 12".

Always store compressor in a horizontal position, on all four rubber mounts.

Moving

When moving the unit into a position for use, grasp handle grips at rear of compressor, and lift compressor high enough so unit can be rolled on the front tire. When location is reached slowly lower rear of compressor to ground.

⚠ Warning: Ensure proper footing and use caution when rolling compressor so that unit does not tip or cause loss of balance.

Air Inlet Filter

Caution: Do not operate without air inlet filter.

General Requirements

The piping, fittings, receiver tank, etc. must be certified safe for at least the maximum working pressure of the unit. Use hard welded or threaded steel or copper pipes, cast iron fittings and hoses that are certified safe for the unit's discharge pressure and temperature. Use pipe thread sealant on all threads, and tighten joints thoroughly to prevent air leaks. **Do not use PVC plastic.**

Condensate Discharge Piping

If installing a condensate discharge line, the piping must be at least one size larger than the connection, as short and direct as possible, secured tightly and routed to a suitable drain point. Condensate must be disposed of in accordance with local, state and federal laws and regulations.

Note: All compressed air systems generate condensate that accumulates in any drain point (e.g. tanks, filter, aftercoolers, dryers). This condensate contains lubricating oil and/or substances which may be regulated and must be disposed of in accordance with local, state, and federal laws and regulations.

Operating Procedures

Pre-Start Checklist

1. Ensure the ON/OFF lever switch is in the OFF position.
2. Ensure tank(s) is/are drained so that moisture, dirt, etc. can be eliminated.
3. Ensure tank pressure gauge reads 0 psi.
4. Ensure safety and drain valve(s) is/are functioning properly.
5. Ensure the drain valve(s) is/are closed.
6. Check oil level in pump.
7. Visually inspect drive belt. Replace belt if frayed, cracked, or worn.
8. Ensure all guards, covers, and labels are in place, legible (for labels) and securely mounted. Do not use compressor until all items have been verified.

Start-Up

1. Ensure the ON/OFF lever is in the OFF position.
2. Pull out and turn regulator knob counterclockwise until fully closed. Push in to lock. Regulated pressure gage should read 0 psi.
3. Plug cord into a grounded wall outlet.

⚠ Warning: Make sure that the correct cord plug end is properly connected to the compressor cordset before operating in 115- or 230-volt mode.

Note: For dual control units, ensure the pilot valve is adjusted to the desired setting (see the Dual Control section in the Common Procedures).

4. Rotate manual lock on pilot valve to an in-line position.
5. Turn the ON/OFF lever to the ON position.
6. Rotate manual lock on pilot valve to a perpendicular position so pump will charge tanks.
7. Allow compressor to pump up to "cut out" pressure.

Note: For constant run operation on units: after the compressor reaches cut-out pressure the unit will continue to run but will not charge air. A slight air noise may be heard, which is the unloading of the air compressor. **For Stop/Start units:** after the compressor reaches cut-out

pressure the unit will turn off and a slight air noise will be heard, which is the unloading of the head through the pressure switch. If unit does not stop, refer to the Dual Control section in the Common Procedures section.

Note: If any unusual noise or vibration is noticed, stop the compressor and refer to the troubleshooting section.

8. Attach hose and accessory.
9. Adjust regulator to desired setting.

Shut-Down

Note: Never stop the air compressor by unplugging it from the power source. This could result in damage to the unit.

1. Move the ON/OFF lever to the OFF position.
Note: If finished using compressor, follow steps 2 - 7 below.
2. Unplug cord from wall outlet.
3. Turn regulator knob counterclockwise until fully closed. Ensure regulated pressure gauge reads 0 PSI.
4. Remove hose and accessory.
5. Drain the air tank(s).
6. Allow the compressor to cool down.
7. Wipe air compressor clean and store in a safe, non freezing area.

Maintenance

The following procedures must be followed when maintenance or service is performed on the air compressor.

1. Turn off air compressor.
2. Disconnect cord from electrical outlet.
3. Drain tank(s).
4. Allow air compressor to cool down before starting service.

Note: All compressed air systems contain maintenance parts (e.g. lubricating oil, filters, separators) that are periodically replaced. These used parts may contain substances that are regulated and must be disposed of in accordance with local, state, and federal laws and regulations.

Note: Take note of the positions and locations of parts during disassembly to make reassembly easier.

Note: Any service operations not included in this section should be performed by authorized service personnel.

Maintenance Chart

Procedure	Day	Week	Month	1 Year or 200 Hrs.
Check pump oil level	X			
Oil leak inspection	X			
Drain condensation in air tank(s)	X			
Check for unusual noise/vibration	X			
Check for air leaks*	X			
Inspect belt	X			
Inspect air filter		X		
Clean exterior of compressor		X		
Check safety relief valve			X	
Check belt adjustment			X	
Change pump oil **				X

* To check for air leaks apply a solution of soapy water around joints. While compressor is pumping to pressure and after pressure cuts out look for air bubbles.

** The pump oil must be changed after the first 20 hours of operation. Thereafter, when using a quality synthetic oil, change oil every 200 hours of operation or once a year, whichever comes first. In harsh environments, maintenance must be performed on a more accelerated schedule.

Compressor Pump Oil Change

Note: Pump oil contains substances that are regulated and must be disposed of in accordance with local, state and federal laws and regulations.

Warning: Aftercooler, pump head, and surrounding parts are very hot; do not touch. (see the Hot Surfaces identified on page 2)

1. Ensure unit is off.
2. Allow the unit to cool.
3. Locate a suitable container under drain plug (P).
4. Remove dipstick (N)
5. Remove the oil drain plug.
6. Allow ample time for all oil to drain out. (Tilting the compressor towards the drain plug will assist in draining.)
7. Reinstall the oil drain plug.
8. Fill pump with a quality synthetic compressor oil. Oil should not exceed top raised line on side of crankcase , the top line on the dipstick or the center of the sight glass.
9. Install dipstick.

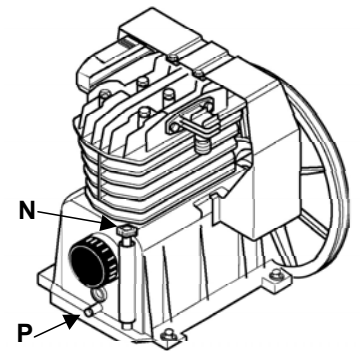

Checking Belt Tension

⚠ Warning: Aftercooler, pump head, and surrounding parts are very hot; do not touch (see the Hot Surfaces identified on page 2).

1. Ensure unit is off and unplugged from wall.
2. Allow unit to cool down so pump can be touched.
3. Using a long screwdriver or similar device, push on the belt in the middle of the span with approximately 8 lbs. of force and notice the amount of deflection. Belt should not more than 1/2"; if so, see Adjusting Belt Tension section.

Adjusting Belt Tension

⚠ Warning: Pump and surrounding components are hot.

1. Loosen four screws on bottom of belt guard.
2. Loosen four pump mounting bolts.
3. Adjust belt tension using the belt tensioning bolt located on the end of the deck.

⚠ Warning: Do not over-tighten. Too much pressure on the belt will cause premature failure to the belt, pump and/or motor.

4. Check belt tension again.
5. Once acceptable tension is reached, retighten pump bolts.

⚠ Warning: Make certain belt alignment is correct, and pump base is parallel with deck. This assures proper flywheel and motor pulley alignment.

6. Retighten belt guard screws.

Accessories

Recommended accessories for use with your tool are available for purchase from your local dealer or authorized service center. If you need assistance in locating any accessory for your tool, contact: J-Air Compressors, 757 Tire Hill Road, Johnstown, PA 15905 or call 1-814-288-5969.

Caution: The use of any other accessory not recommended for use with this tool could be hazardous.

Service Information

Please have the following information available for all service calls:

Model Number _____

Serial Number _____

Date and Place of Purchase _____

Repairs

To assure product SAFETY and RELIABILITY, repairs, maintenance and adjustment should be performed by authorized service centers or other qualified service organizations, always using compatible replacement parts.

Full One Year Warranty

J-Air compressors are warranted for one year from date of purchase. We will repair, without charge, any defects due to faulty materials or workmanship. For warranty repair information, call 1-814-288-5969. This warranty does not apply to accessories or damage caused where repairs have been made or attempted by others. This warranty gives you specific legal rights and you may have other rights which vary in certain states or provinces.

TROUBLESHOOTING GUIDE

This section provides a list of the more frequently encountered malfunctions, their causes and corrective actions. The operator or maintenance personnel can perform some corrective actions, and others may require the assistance of a qualified J-Air technician or your dealer.

Problem Code

Compressor does not start or restart	16,17,18,19,20,36
Unit does not or is slow to come up to speed	3,8,11,12,14,15,20,21,22,24,25,31
Air compressor not making enough air.....	1,3,7,8,9,10,11,21,24,25,28,29
Insufficient pressure at air tool or accessory	1,3,7,8,9,10,11,21,24,25,27,28,29
High oil consumption.....	2,6,9,10,11,12,15,30,32
Unit runs excessively hot	1,2,4,5,10,11,12,13,15,19,30
Excessive starting and stopping	7,20,21,24,25,29
Excessive noise during operation	2,3,4,5,8,9,10,11,12,15,25,29,30,31
Moisture in discharge air.....	34,35
Moisture in crankcase or "milky" appearance in petroleum lubricant or rusting in cylinders	6,7,9,10,15,25,26,33,35
Oil in discharge air (oil pumping)	2,6,8,9,10,11,15,31,32
Oil leaking from shaft seal.....	12
Safety relief valve "pops"	22,23
Air leaks at pump	24,25
Air leaks at fittings	25
Air leaks from tank	26
Abnormal piston ring or cylinder wear	2,4,5,6,9,10,11,13

Code	Possible Cause	Possible Solution
1.	Clogged or dirty inlet and or discharge line filter.	Clean or replace.
2.	Lubricant viscosity too low or too high.	Drain existing lubricant and refill with a quality synthetic lubricant.
3.	Lubricant viscosity too high.	Drain existing lubricant and refill with a quality synthetic lubricant.
4.	Lubricant level too low.	Add lubricant to crankcase to proper level. Check for bearing damage.
5.	Detergent type lubricant being used.	Drain existing lubricant and refill with a quality synthetic lubricant.
6.	Extremely light duty cycles.	Run unit for longer duty cycles.
7.	Compressor check valve leaky, broken, carbonized or loose.	Clean or replace as required. Inspect valves.
8.	Carbon build up on top of piston.	Clean piston. Repair or replace as required.
9.	Piston rings damaged or worn (broken, rough, or scratched). Excessive end gap or side clearance. Piston rings not seated, are stuck in grooves or end gaps not staggered.	Install new rings.
10.	Cylinder or piston scratched, worn, or scored.	Repair or replace as required.
11.	Connecting rod, piston pin, or crankpin bearings worn or scored.	Inspect all. Repair or replace as required.
12.	Crankshaft seal worn or crankshaft scored.	Replace seal or crankshaft assembly.
13.	Extremely dusty atmosphere.	Install more effective filtration or relocate unit.
14.	Ambient temperature too low.	Relocate unit to warmer environment. Ensure quality synthetic oil is in crankcase
15.	Worn cylinder finish.	Deglaze cylinder with 180 grit flex-hone.
16.	Power cord not plugged in.	Plug cord into grounded outlet.
17.	Motor thermal overload switch has tripped.	Turn air compressor off. Wait until motor is cool, then press motor thermal overload button firmly until click is heard (located on motor.).
18.	Fuse blown or circuit has tripped.	Replace fuse or reset circuit breaker. Check for proper fuse; only "Fusetron" type T fuses are acceptable. Check for low voltage conditions. Disconnect any other electrical appliances from circuit or operate air compressor on its own branch circuit.
19.	Wrong gauge wire or length of extension cord.	Check chart on page #3 for proper gauge wire and cord length. If possible, eliminate extension cord.
20.	Defective motor, motor capacitor or pressure switch.	Contact J-Air Customer Service at 1-814-288-5969.
21.	Air compressor is not large enough for air required.	Check the accessory air requirement. If it is higher than the CFM or pressure supply of the air compressor, you need a larger air compressor.
22.	Possible defective safety/relief valve.	Operate safety relief valve manually by pulling on test ring. If it still leaks, replace.
23.	Excessive air tank pressure.	Adjust pilot valve. If problem still exists, replace pilot valve.
24.	Defective gaskets.	Replace and torque head bolts to 19 ft lb.
25.	Fittings not tight enough.	Warning: Drain air before tightening; tighten fittings where air cannot be heard escaping. Check joint with soap solution. Do not over tighten.
26.	Defective or rusted air tank.	Air tank must be replaced. Do not attempt to repair air tank.
27.	Pressure regulator knob not turned to high enough pressure.	Adjust pressure regulator knob to proper setting or replace defective pressure regulator.
28.	Hose or hose connections are too small or long.	Replace with larger hose or connectors.
29.	Possible defective valve.	Remove pump head and inspect valve plate and valve. Clear or replace valves as required.
30.	Air compressor on uneven surface.	Do not incline the air compressor more than 10° in any direction while running.
31.	Crankcase overfilled with oil.	Drain oil. Refill to proper level with a quality synthetic oil.
32.	Plugged oil crankcase vent.	Clean.
33.	Water in oil due to condensation.	Drain oil. Refill to proper level with a quality synthetic oil.
34.	Condensation in air tank caused by high level of atmospheric humidity.	Drain air tank after every use. Drain air tank more often in humid weather and use an air line filter.
35.	Unit located in damp or humid location.	Relocate unit.
36.	Tanks have air pressure.	Bleed tanks fully.